

ENC-A5DN Differential Encoder without Index Channel



FEATURES

- Accepts +/- 0.010" Axial Shaft Play
- 32 to 1,250 Cycles Per Revolution (CPR)
- Tracks 0 to 300,000 Cycles Per Second
- Powered From a Single +5VDC Power Supply
- 2-Channel Quadrature Differential Squarewave Outputs
- Operating Temperature of -40° to +100° C
- RoHS Compliant and REACH Certified



DESCRIPTION

ENC-A5DN is a differential encoder designed for quick and simple assembly to any shaft with a minimum length of .445" and maximum length of .570", and accepts shaft sizes ranging from .079" to .394" in diameter. The ENC-A5DN module is designed to detect the rotary position with a code wheel. When attached to the end of a shaft, the encoder provides digital feedback information. This differential encoder consists of a LED source lens and a monolithic detector IC enclosed in a small polymer package. These modules implement phase array detector technology providing superior performance and tolerances over traditional aperture mask type encoders. The ENC-A5DN series provides digital quadrature differential outputs on all resolutions and are capable of sinking or sourcing 8 mA each. These encoders are powered from a single +5VDC power supply and are RoHS compliant and REACH certified.

ORDERING INFORMATION

ENC - A5DN - 0050 - 394 - H - G

CPR		
0032	0250	0540
0050	0256	0720
0096	0360	0900
0100	0400	1000
0192	0500	1024
0200	0512	1250

Bore Size	
079 = 2mm	236 = 6mm
118 = 3mm	250 = 1/4"
125 = 1/8"	276 = 7mm
156 = 5/32"	313 = 5/16"
157 = 4mm	315 = 8mm
188 = 3/16"	375 = 3/8"
197 = 5mm	394 = 10mm

Cover Options
E = Cover Extension
H = Hole in Cover
Blank = Default

Base Options
3 = Base Mounting Holes Become 0.125"
A = Adds Self-Aligning Shoulder to Base
G = Adds 1.812" Mounting Ears to Base
R = Adds 3-Slot Adapter to Bottom of Base
Blank = Default

L010728

DEFAULT OPTION:

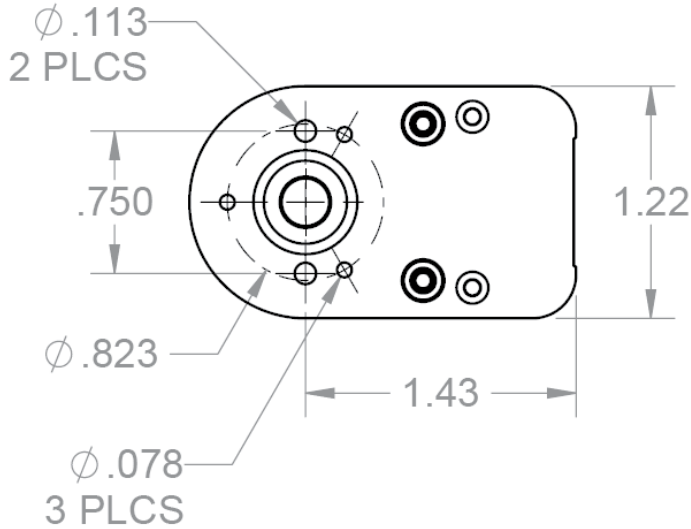

Note: Dimensions are in inches

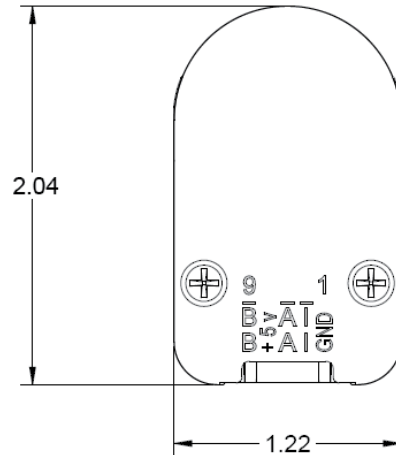

E-Option:

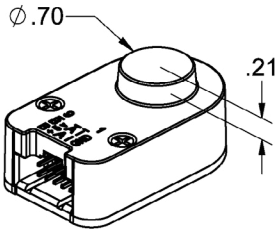

H-Option:

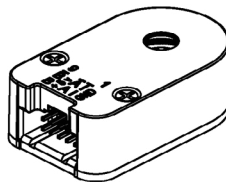

Default Option:

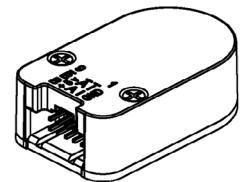

Note: Dimensions are in inches

Cover Options:	Description
E - Option	E-Option provides a cylindrical extension cover for larger shafts. The required shaft length is .445" to .750". Note: E-option + R-Option the required shaft length is .570" to .875".
H - Option	Shafts 2mm to 1/4", a .295" diameter hole is supplied. Shafts 5/16" to 10mm, a .438" diameter hole is supplied. Required shaft length > 0.445" Note: H-Option + R-Option the required shaft length is > .570"
Default Option	The required length is .445" to .570" Note: Default Option + R-Option the required shaft length is .570" to .695"

3-OPTION:

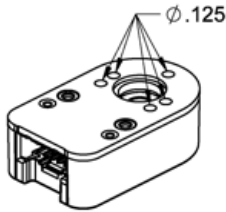

3-Option: Makes all five hole diameters .125"

A-OPTION:

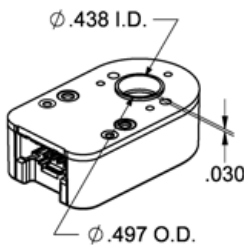

A-Option: Adds a .497" diameter alignment shoulder designed to slip into a .500" diameter recess in the mounting surface centered around the shaft.

R-OPTION:

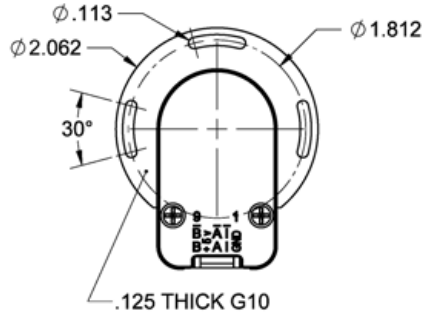

R-Option: Adapter is an 1/8" thick fiberglass adapter which is pre-mounted to the base of the encoder. It allows the encoder to rotate +/- 15 degrees.

*This option adds 1/8" to the required shaft length.

G-OPTION:

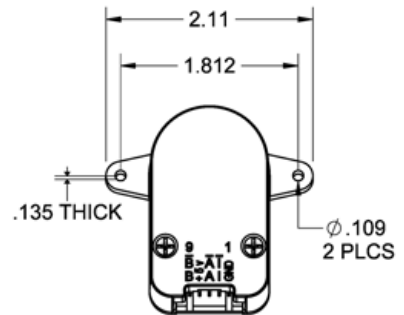

G-Option: Includes molded ears which enables it to be mounted to a 1.812" diameter bolt circle. Mounting holes are designed to fit 4-40 screws. Will work with shaft lengths of .445" to .570" and does not add to the required shaft length.

Note: All dimensions are in inches

(Note: Base Mounting Screws are NOT included. #2-56 or #4-40 screws can be used to mount the base to your mounting surface.)

Differential Encoder Timing Diagram

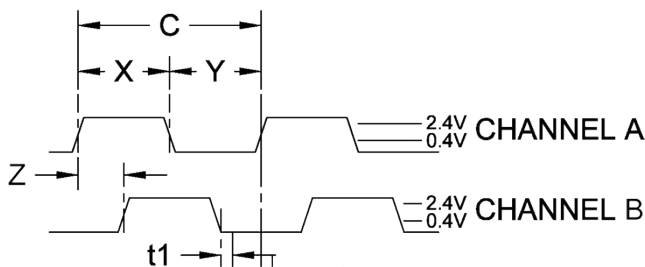

ROTATION:
CW - B LEADS A, CCW - A LEADS B

DIFFERENTIAL ENCODER PINOUT

TOP OF ENCODER FACING PLUG

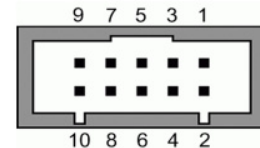

Pin #	Function
1	Ground
2	Ground
3	No Connection
4	No Connection
5	A-Channel
6	A+Channel
7	Power
8	No Connection
9	B-Channel
10	B+Channel

Model #	Description
CPR(N):	The Number of Cycles Per Revolution
One Shaft Rotation:	360 mechanical degrees, N cycles
One Electrical Degree (°e):	1/360th of one cycle
One Cycle (C):	360 electrical degrees (°e). Each cycle can be decoded into 1 or 4 codes, referred to as X1 or X4 resolution multiplication
Symmetry:	A measure of the relationship between (X) and (Y) in electrical degrees, nominally 180 °e
Quadrature (Z):	The phase lag or lead between channels A and B in electrical degrees, nominally 90 °e
Index (CH I):	The Index Output goes high once per revolution, coincident with the low states of channels A and B, nominally 1/4 of one cycle (90°e)

Timing Characteristics	Symbol	Min	Typ	Max	Units
Cycle Error	C	-	3.0	5.5	°e
Symmetry	X,Y	150	180	210	°e
Quadrature	Z	60	90	120	°e
Index Pulse Width	Po	60	90	120	°e
Ch. I Rise After Ch. B or Ch. A Fall	t1	10	100	250	ns
Ch. I Fall After Ch. B or Ch. A Rise	t2	70	150	300	ns

Parameter	Max	Units
Vibration (5 to 2kHz)	20	g
Shaft Axial Play	+/- 0.01	in.
Shaft Eccentricity Plus Radial Play	0.004	in.
Acceleration	250,000	rad/sec ²

Parameter	Min	Typ	Max	Units
Supply Voltage	4.5	5.0	5.5	Volts
Supply Current				
CPR < 500, no load	-	29	36	mA
CPR ≥ 500 and < 2000, no load	-	57	65	
CPR ≥ 2000	-	73	88	
Output Low (I _{OL} = 8mA max)	-	0.2	0.4	Volts
Output High*				
I _{OL} = -8mA max	2.4	3.4	-	Volts
Differential Output Rise/ Fall Time	-	-	15	nS

* Unloaded high level output voltage is 4.80V typically, 4.2V minimum.

Recommended Operating Conditions	Min	Max	Units
Temperature (CPR < 2000)	-40	100	°C
Temperature (CPR ≥ 2000)	-25	100	°C
Load Capacitance	-	100	pF
Count Frequency (CPR ≤ 1250)	-	300	kHz
Count Frequency (CPR 2000-2500)	-	360	kHz
Count Frequency (CPR 4000+)	-	720	kHz

Speed Calculation	Units
CPR < 2000	18x10 ⁶ / CPR RPM
CPR ≥ 2000 and < 4000	21.6x10 ⁶ / CPR RPM
CPR ≥ 4000	43.2x10 ⁶ / CPR RPM

*60,000 RPM is the maximum RPM due to mechanical limitations.

Cables:

The following cables are compatible with Anaheim Automation's A5DN series encoder. Select a cable length from the table below:

Cable Part Number	Length
ENC-CBL-AA4707	1 ft.
ENC-CBL-AA4707-5	5 ft.
ENC-CBL-AA4707-10	10 ft.
ENC-CBL-AA4707-20	20 ft.

NOTE: For pricing and other information on cables and centering tools, please visit Accessories on our website.

Centering Tools:

Centering tools are optional, but recommended for a more precise installation.

ENC-CTOOL - 250

Bore Size	
079=2mm	236=6mm
118=3mm	250=1/4"
125=1/8"	276=7mm
157=4mm	313=5/15"
188=3/16"	375=3/8"
197=5mm	394=10mm